



**BIA – AUTOSUB 810335**

**BIA – AUTOSUB-X 810341**

## User Manual



# Introduction





Thank you for selecting a BIANCO AUTOSUB Pump.

The Bianco AUTOSUB is specially designed and manufactured for the rainwater industry. Being a submersible design means that the pump can be placed inside the rainwater tank for a neat, secure and quiet installation for the automatic supply of clean water in domestic applications.

Whether you have selected the standard version or the 'X' variant for use with a floating intake you find these are uncomplicated electrical appliances.

The purpose of this manual is both to ensure user safety and to prolong the lifespan of the product by highlighting 'best practice'.

Benefits	Features	Cautions
<ul style="list-style-type: none"> <li>• Light and compact - easy to use</li> <li>• Standard version with filter screen or 'X' model for use with floating intake</li> </ul>	<ul style="list-style-type: none"> <li>• Quality pump materials and construction to ensure reliable operation</li> <li>• Automatic On/Off</li> </ul>	<ul style="list-style-type: none"> <li>• Not intended for submersion greater than 7m</li> <li>• Not intended for continuous operation such as water features or fountains</li> <li>• Not for use with biological wastewaters</li> </ul>

	Warning - Electrical safety
	Warning – Potential consequences of use outside of intended application(s). Includes environmental condition warnings.
	Mandatory warning
	Warning to disconnect power
	Read carefully

## Technical information

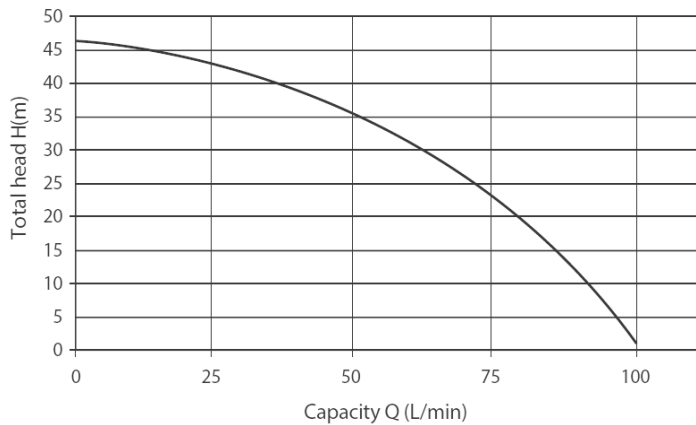





**NEVER** use the AUTOSUB to pump:

- Water with high sand or solids content.
- Saltwater
- Biological wastewaters
- Corrosive, easily combustible, aggressive, or explosive liquids such as petroleum products

RATED POWER (W)	750W	RATED VOLTAGE	220 – 240V 50Hz
MAX. FLOW [LPM]	100 lpm	RATED CURRENT	5.3 Amps
MAX. HEAD [M]	45m	POWER CABLE LENGTH	10m H07RNF
WORKING TEMPERATURE	< 40°C	PROTECTION CLASS	IPX8
LIQUID TEMPERATURE	3 - 35°C	IMPELLERS	4
MAX. IMMERSION DEPTH	7m	HYDRAULIC BODY and INLET STRAINER	(20%) Glass reinforced Polypropylene
MAX. DIA. OF PARTICLE	< 1mm	OUTLET	1" BSPF
MOTOR DUTY	S1 Continuous	SEALS	Twin Mechanical Seal
MOTOR PROTECTION LEVEL	Class F	AUTOMATIC FUNCTION	iSENSOR Auto Control + Fixed Arm Float Switch
MOTOR PROTECTION	Auto resetting thermal overload	NET WEIGHT [KG]	12 kg
CAPACITOR	10UF +/-5% 450V	PACKAGE DIMENSION	350 x 240 x 540mm
MOTOR SHAFT	Stainless steel		

## Warnings

	Prior to starting installation or any maintenance the pump must be disconnected from the power supply and pressure relieved from the system including pump and associated pipework.
	Any changes or modifications, especially to the wiring, must be carried out by suitably qualified personnel.
	To avoid excessive thermal shock to the motor the pump should not start more than 20 times during any 1-hour period.
	This appliance is not intended for use by persons (including children) with reduced physical, sensory or mental capabilities, or lack of experience and knowledge, unless they have been given supervision or instruction concerning use of the appliance by a person responsible for their safety. Children should be supervised to ensure that they do not play with the appliance.
	Running the pump without water or allowing the pump to run dry will damage the seal voiding the warranty

## Electrical Connections



Avoid handling the pump unless the power supply has been isolated.



The pump should be grounded to prevent electrical leakage and should be equipped with a leakage protection switch with a protection current not exceeding 30mA.

- All electrical connection(s) and protection(s) should be carried out in accordance with local regulations.
- The electrical specifications are marked on the nameplate. Please ensure that the motor matches the power supply voltage.
- If the pump is installed some distance from the power supply, the power supply cabling should be sized appropriately to avoid voltage drop.
- Avoid damage to the power cord. Should damage occur, do not use the pump. It should be repaired or replaced by professional or authorized personnel.
- Note that the length of the pump's power cord is intended to limit the pump submersion dept.
- Ensure sure that the plug and socket of the plug cord are kept dry.

## Standards and Approvals



**SAA Approvals** is accredited by the Joint Accreditation Service of Australia and New Zealand (JAS-ANZ) as a third party certification body to issue of Certificates of Approval for declared and non-declared electrical equipment that has proven to comply with the safety requirements of the applicable Australian Standard.



**CE marking** is a certification mark that indicates conformity with health, safety and environment. The CE marketing represents a manufacturer's declaration that products comply with the EU's New Approach Directives. These directives not only apply to products within the EU but also for products that are manufactured in or designed to be sold in the EEA.



This approval ensures that the pump will not contribute any toxic materials or metals to the liquid being pumped, won't support the growth of micro-organisms and won't change the taste or appearance of your water

## Installation



Avoid using the power cable to hang or lift the pump or hang the pump.

Tie a rope to the pump handle to allow before submerging in the water.

After lowering approx. 12cm into the water the air will exit the pump via the bleed holes.

**AUTOSUB** Secure the pump at least 30cm above the base of the tank to prevent impurities, such as cement fines from clogging the filter screen.

**AUTOSUB-X** fitted with a floating intake is able to sit on the bottom of the tank

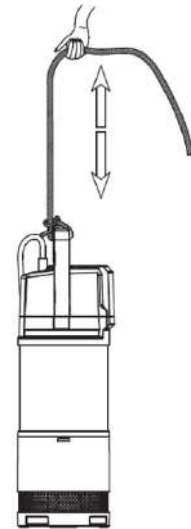

Avoid running the pump in a no-load condition.

## Operation

The BIANCO AUTOSUB is equipped with a pressure sensor and a flow sensor to automatically control the start and stop of the water pump.

To avoid frequent and unnecessary pump restarts, to achieve greater energy savings and ensure correct operation, it is important to install a pressure tank. 

The pump starts when the pump senses the pressure in the system has fallen to 2.5 bar. **The pump does not start immediately when a tap is opened.**

Once all taps are closed the pump will sense that the flow has ceased. The pump will continue to run for an additional 10 seconds before shutting down.

If there are leaks in the system the pump may not shut down.

### **No-load / Dry run protection:**

There is a 3 second delay to the pump starting after powering on.

The fixed arm float fitted to the pump prevents it operating if there is insufficient water

Additional to the low level float, if there is no water present the pump will run for 30 seconds then stop for 5 seconds.

This cycle (30 seconds run, 5 second stop) repeats three times. After the third cycle the pump will suspend its operation for 24 hours.

For best service life the pump maximum pump starts per hour should not exceed 20 of, evenly spaced.

## Maintenance and Cleaning

Under normal operating conditions, the BIANCO AUTOSUB pump does not require any special maintenance

### Filter and base cleaning

Should the pump ingest sediment it is strongly recommended to flush the pump in clear water.

In the case of heavy contamination, it may be necessary to remove the pump base to clear obstructions.



**Danger! Risk of electric shock and injury!**  
Isolate the power supply of the water pump before maintenance and cleaning.

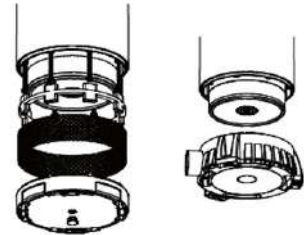

- Use a screwdriver to unscrew the eight screws ④
- Remove the base ③ from the pump
- Remove the filter ② and bracket ① from the pump respectively
- Clean the impurities on the base ③, filter ② and bracket ①
- After cleaning, install the bracket ① on the water pump and install the filter ② and the base ③ in the order of installation
- Install the eight screws ④ with a screwdriver

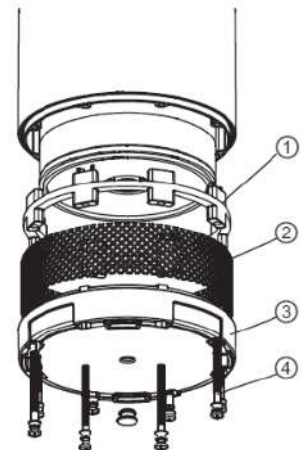

The manufacturer is not responsible for the consequences of any unauthorized repairs and changes. To ensure safety, the spare parts used for repair must be original parts provided by the manufacturer or spare parts provided by the manufacturer licensed by the manufacturer.



**The pump must not be disposed of with normal household waste  
Dispose of in accordance with local environmental regulations.**

## Trouble Shooting



Before inspecting the pump, disconnect the power supply (i.e. remove the plug from the socket). If there is any damage to pump or power cable any necessary repairs or replacements must be performed by the manufacturer or his authorised customer support service, or by an equally-qualified technician.

	Possible cause	Potential Solution
The motor does not start and there is no noise;	A. Check the power supply to the pump	Check power supply fuses/circuit breakers
The pump will not start correctly but makes a noise	A. Possible partial blockage B. Capacitor failure	
Pump flow rate is poor	A. Clogged water inlet filter B. Blocked or damaged impellers C. The total head requirement exceeds the pump potential	Clear the blockage Remove obstacles or replace the impellers
Water doesn't flow when a tap is closed and reopened	A. Inspect any check valves for blockage	
The flow has decreased over time	A. Partial blockage of the water inlet filter; B. The impeller is partially blocked or the outlet pipe is partially blocked;	Remove obstacles
The pump runs for a period of time then switches off unexpectedly.	A. The thermal overload protection device may have operated to stop the water pump automatically.	The fluid density or fluid temperature may be too high causing the motor to overheat: A small water demand may be causing the pump to start and stop excessively

# 11. Warranties – Terms and Conditions

This warranty is given in addition to the consumer guarantees found within the Australian Competition and Consumer Act 2010 (Cth) for goods purchased in Australia and the Consumer Guarantees Act 1993 NZ for goods purchased in New Zealand:

1) White International Pty Ltd / White International NZ Ltd (White International) warrant that all products distributed are free from defects in workmanship and materials, for their provided warranty period as indicated on the top or opposite side of this document. Subject to the conditions of the warranty, White International will repair any defective products free of charge at the premises of our authorised service agents throughout Australia and New Zealand if a defect in the product appears during the warranty period. If you believe that you have purchased a defective product and wish to make a claim under this warranty, contact us on our Sales Hotline on 1300 783 601, or send your claim to our postal address or fax line below and we will advise you as to how next to proceed. You will be required to supply a copy of your proof of purchase to make a claim under this warranty.

2) This warranty excludes transportation costs to and from White International or its appointed service agents and excludes defects due to non-compliance with installation instructions, neglect or misuse, inadequate protection against the elements, low voltage or use or operation for purposes other than those for which they were designed. For further information regarding the suitability of your intended application contact us on our Sales Hotline on 1300 783 601. If you make an invalid claim under this warranty, the original product will be sent back to you unrepai red.

3) This warranty refers only to products sold after the 1st January 2022, and is not transferable to another product type and only applies to the original owner, purchaser or end user, and is in addition to the consumer guarantees found within the Competition and Consumer Act 2010 (Cth) for goods purchased in Australia and the Consumer Guarantees Act 1993 (NZ) for goods purchased in New Zealand.

4) Our goods come with guarantees that cannot be excluded under the Australian Consumer Law. You are entitled to a replacement or refund for a major failure and for compensation for any other reasonably foreseeable loss or damage. You are also entitled to have the goods repaired or replaced if the goods fail to be of acceptable quality and the failure does not amount to a major failure. 2 YEAR WARRANTY.

5) To the fullest extent permitted by law, White International excludes its liability for all other conditions or warranties which would or might otherwise be implied at law. To the fullest extent permitted by law, White International's liability under this warranty and any other conditions, guarantees or warranties at law that cannot be excluded, including those in the Competition and Consumer Act 2010 (Cth), is expressly limited to: (a) in the case of products, the replacement of the product or the supply of equivalent product, the payment of the cost of replacing the product or of acquiring an equivalent product or the repair of the product or payment of the cost of having the product repaired, is at the discretion of White International or a 3rd party tribunal elected under the Competition and Consumer Act 2010 (Cth) for goods purchased in Australia and the Consumer Guarantees Act 1993 (NZ) for goods purchased in New Zealand; and

6) To the fullest extent permitted by law, this warranty supersedes all other warranties attached to the product or its packaging.

7) In the case of services, supplying the services again or the payment of the cost of having the services supplied again, is at the discretion of White International or a 3rd party tribunal elected under the Competition and Consumer Act 2010 (Cth) for goods purchased in Australia and the Consumer Guarantees Act 1993 (NZ) for goods purchased in New Zealand. 8) Our warranty commences from the date of purchase of the above mentioned pumps. Proof of purchase is required before consideration under warranty is given.

*Record your date of purchase in the space below and retain this copy for your records.*

**Date of Purchase** .....

**Model Purchased** .....





**[www.whiteint.com.au](http://www.whiteint.com.au)**  
**[www.whiteint.co.nz](http://www.whiteint.co.nz)**

**Please always refer to our website for further technical information & new product innovations**

**Disclaimer:** Every effort has been made to publish the correct information in this manual.  
No responsibility will be taken for errors, omissions or changes in product specifications.

© 2020 Copyright White International Pty Ltd

**TM ® - WARNING:** Please be aware that various brands & products depicted within this document are subject to trademark, patent or design registrations. Infringement of any intellectual property contained within this document without express written authority by the appropriate intellectual property holder may result in further legal action to be taken. For any queries regarding use of the contained information please feel free to contact White International Pty Ltd.